

Capacity:

Stage 1: 229 m Te (251 Sh. tonnes)
 Stage 2: 148 m Te (163 Sh. tonnes)
 Stage 3: 81 m Te (89 Sh. tonnes)

Weight:

Appr. 7000 kg / 15432 lbs
 (ex. oil, reservoir cap: 410 L / 108 USgal)

Roll Dimensions (1 : 4)

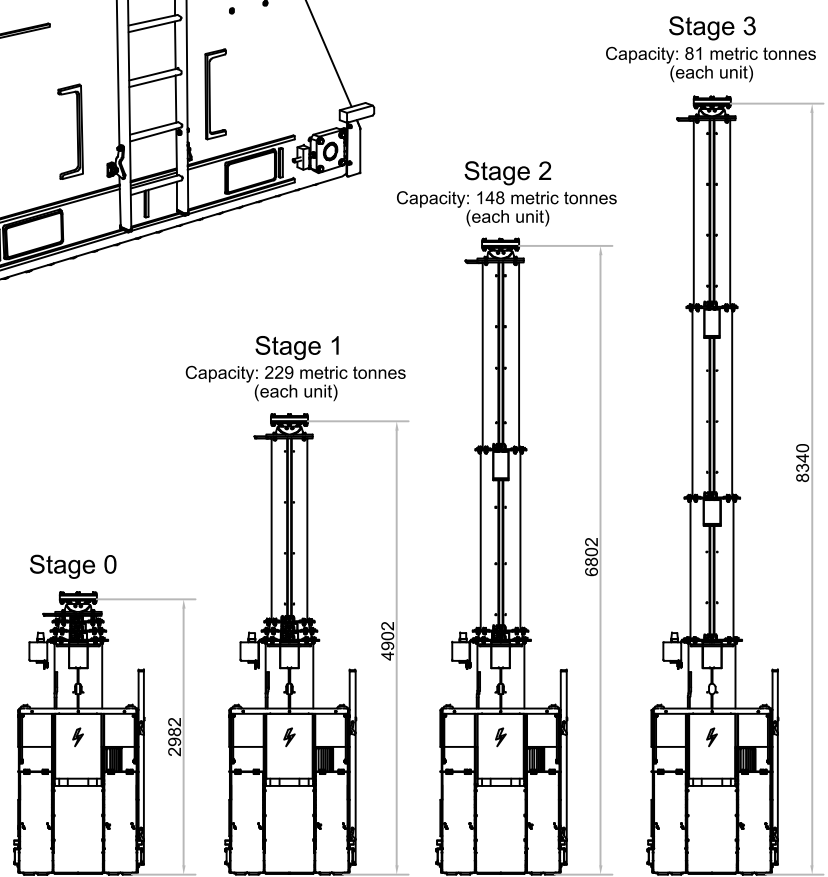
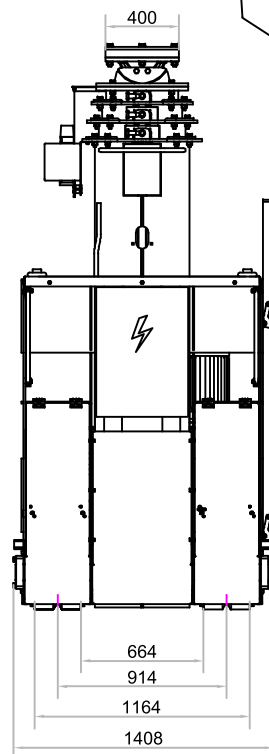
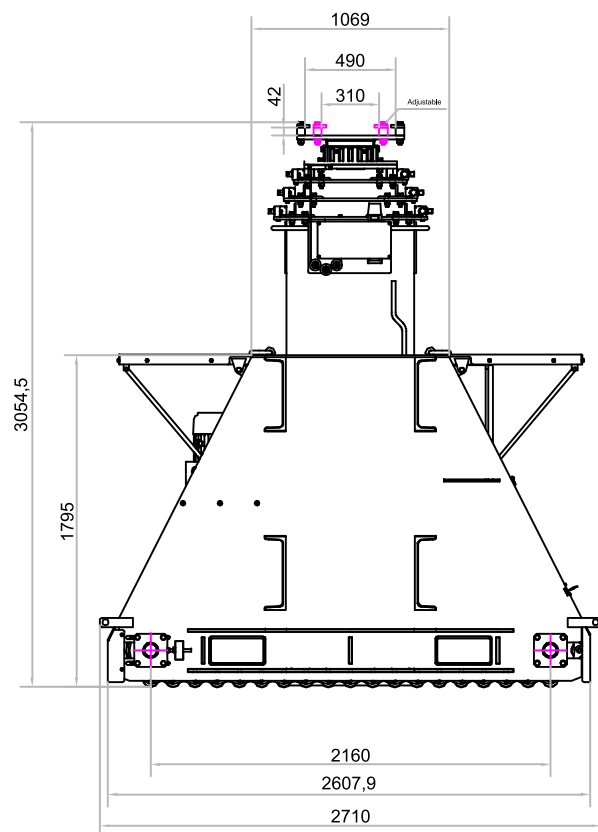
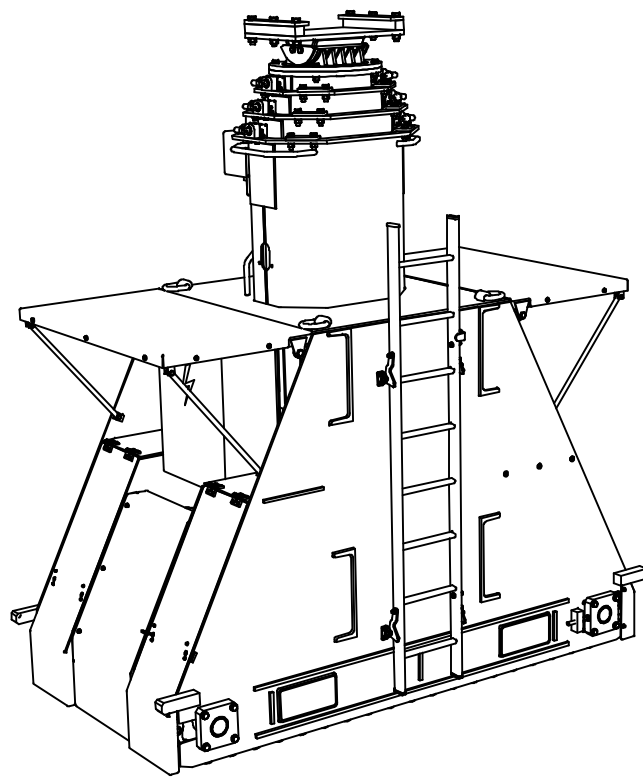
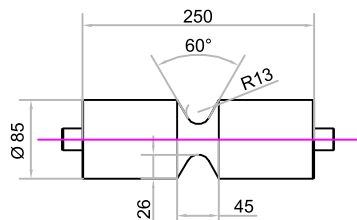

GETEKEND: C. K.	ORDER NUMMER	MATERIAAL	VERVILDER BRANEN VAN KRUISENDE BORINGEN.	TOLERANTIE TENZIJ ANDERS VERHELD
DATE: 06-10-2008	SCHAAL: 1:20	KEUR: Lloyds	RIJPEID ALGEMEEN	SO. 5.3
OPPAALSTRAAT 44, 7534 TS HENGELD HOLLAND POSTBUS 451, 7530 AK HENGELD HOLLAND TELEFON: 074-2430345 FAX: 074-2430338 E-MAIL: INFO@HYDROSPEX.NL		ONDERDEEL NAAM: SBL1000-SP		
AUTEURSRECHTEN VOORBEHOUDEN VOLGENS DE WET		TEK. NO:	03046.01.00.00	REV: FDR: A2